

windmason  
BREATHE THE FINEST

## Air-cooled Chiller Unit

WM-ACCH Series

REVOLUTIONARY COOLING, HEATING, HUMIDIFICATION & REFRIGERATION  
SOLUTION FOR HEALTHY FUTURE

windmason Arabia Company

شركة مصنع ويندماسون العربية



2024  
www.windmason.com



# PRODUCT INTRODUCTION

## Overview

The WM-ACCH series air-cooled chiller units are single refrigeration circuit with shell and tube evaporator, high efficiency air cooled condenser, low noise fan and required electromechanical control panel, powder coated galvanized steel body panels, and base frame. fully enclosed box with perforated screen for air flow of condenser fan. simple in and out water connection with union. auto temperature control, compressor low and high pressure protection. overload protection,

It can be widely used in new and rebuilt industrial and civil buildings, such as hotels, hotels, entertainment centers, hospitals, restaurants, office buildings, movie theaters, factories, supermarkets and other places, especially suitable for noise and surrounding environment have high requirements, water shortage and should not be installed cooling tower occasions. The module has flexible installation, can be phased investment, and the construction period is short, no cooling water system, simple pipeline, moderate investment, and has become one of the preferred forms of air conditioning system for many users.



## Nomenclature

WM

①

ACCH

②

30K

③

5DT

④

- ① **WM** Windmason
- ② **ACCH** Air Cooled Chiller
- ③ **30K** 30 thousand btu/h
- ④ **5DT** 5 °C degree evaporator temperature delta.



## Energy Conservation And Emission Reduction

ACCH series adopts the efficient and environmentally friendly R410A refrigerant and its ODP is 0, which means the products will not destroy the atmospheric ozone layer. A maximum cooling capacity of unit volume that requires a much smaller refrigerant charge compared to traditional refrigerants could help reduce greenhouse gas emissions.



## Industry-leading Comprehensive Energy Efficiency

With an internationally well-known scroll compressor, a shell and tube evaporator, a highly-efficient barrel-type heat recovery system, accurate flow control technology of the electronic expansion valve, and innovative system design, the unit can reach the optimum configuration proportion in each mode, thus greatly raising operation efficiency. Integrated energy efficiency ratio of the unit is up to 7.62, which is industry-leading.

## Accurate Adjustment, Energy-saving Operation

Compared to traditional air-cooled module units that use capillary tube, ACCH module use high quality adjusted thermal expansion valves for freon regulation, This results in real-time system control. Dynamic matching improves the accuracy of water temperature control, enhancing the efficiency of each component in the system. This allows the unit to operate stably at any load and adapt automatically to changing environmental conditions. Thoroughly solve the oscillation problem of the refrigeration system to achieve more stable temperature output and uniform indoor temperature, improving human comfort.

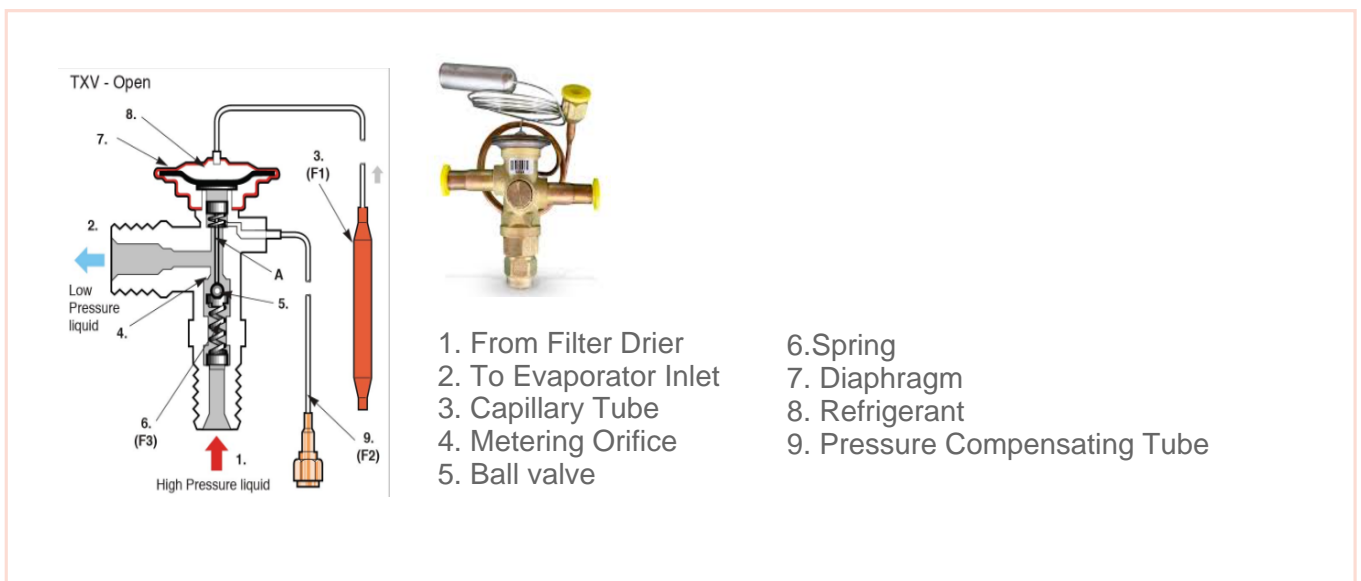



## Stable And Reliable With High Quality Components

- **Vacuum Brazed Shell and tube Heat Exchanger Evaporator**

The high efficiency shell and tube heat exchanger adopts a unique six-helix structure, compact structure, and an efficient heat exchange tube inside. Its heat exchange area is 3.7 times that of the light tube. The ribs outside the tube and the ridges inside the tube can cause strong turbulence of refrigerant and water, greatly improving the heat transfer efficiency and high heat exchange efficiency.

Using a unique six-spiral structure, self-scaling ability is strong, not easy to scale, anti-freezing ability is strong, not easy to freeze crack, waterway circulation cross-sectional area is large, not easy to plug. The water side pressure is up to 1.6MPa, and the alternating and parallel arrangement design ensures more uniform water flow distribution, so that the heat transfer of the two systems is balanced.

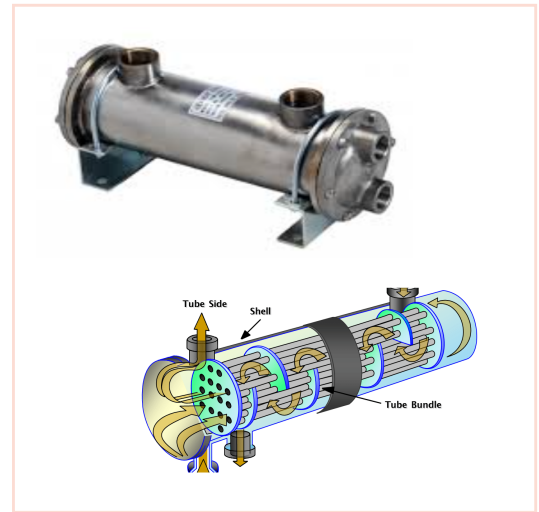

- **Efficient air cooled condenser heat exchanger**

The copper tube and aluminum fins air to liquid heat exchanger condenser provide optimum efficiency even in high ambient conditions. the fins are 13 to 16 FPI with wavy structure, which provide high efficient heat transfer and provide turbulent air flow to use each particle of air touch the surface. the reinforced galvanized steel frame provide strength and durability to the structure of the coil. direct driven axial fan smooth operation and high efficiency air flow, low power consumption, low noise.

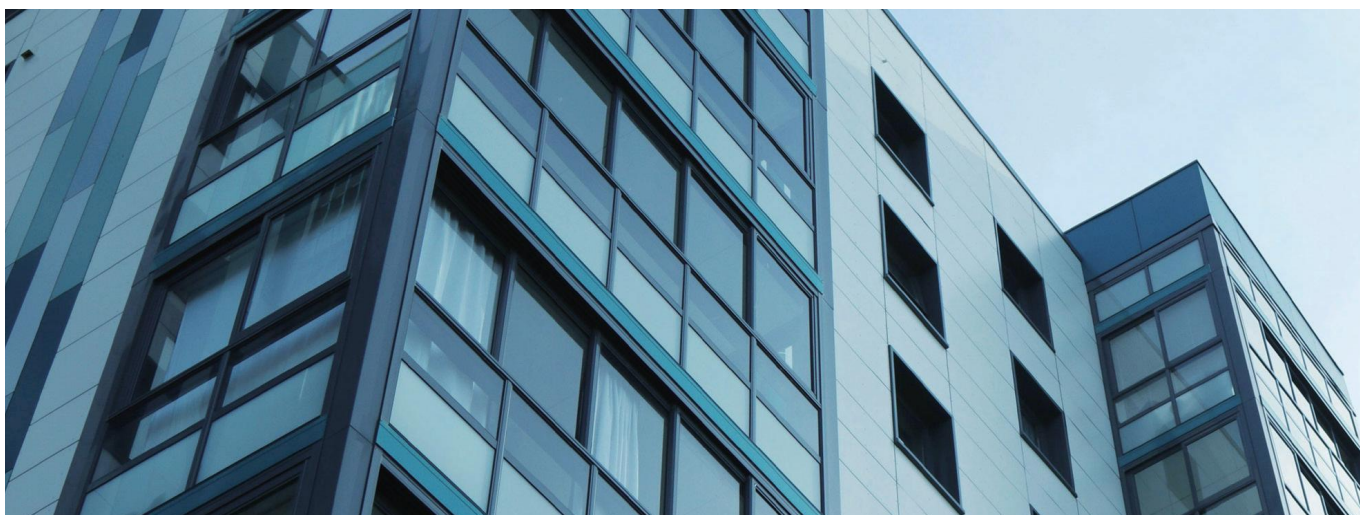





## Control System

---

The unit adopts a control system and a temperature display controller, which is simple and fast to use.

### Intelligent Wiring Controller Function

- Switching between cooling and heating working modes if the unit is hot and cool.
- Parameter setting function: real-time time setting, inlet/outlet temperature, antifreeze temperature,
- Electro-Mechanical controller
- Compressor overload protection.
- Switch on/off control function
- Start and stop control function of chilled water pump
- Temperature controller functions.
- Water system two-way valve control function
- Terminal two-way valve interlocking control function

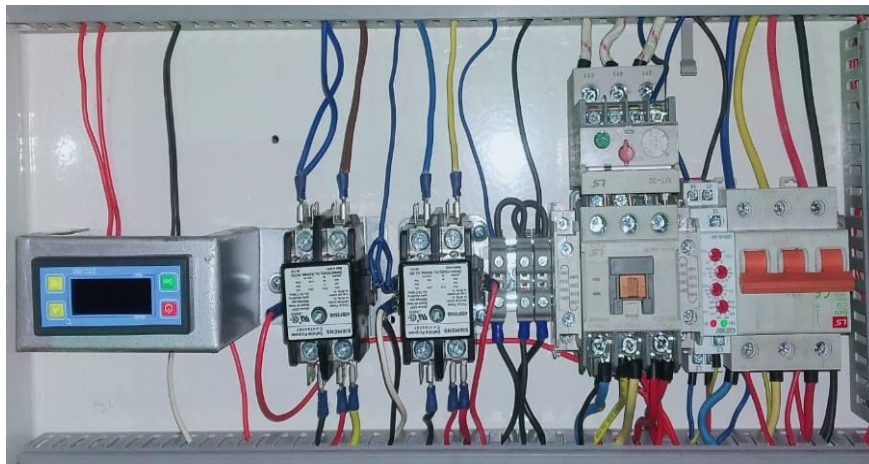

Control Panel



# UNIT SPECIFICATIONS

## ACCH Series Unit Specification

Technical Data	
Model	WM-ACCH-30K-5DT
Nominal Capacity	2.5 TR / 30000 btu/h
Condenser Type	Air cooled
Compressor	Scroll - single circuit
Refrigerant	R134A / R410A / R404 / R407 - as per available compressor
Water in Temperature	35.0 C
Water out Temperature	15.0 C
Evaporator /Cooler Delta Temp.	20.0 C
Water flow Max.	200 l/h
Power input / Current	3.2 kW / 18 A
Electrical Power	220v/1ph/60hz
Refrigerant charge	2.2 kg
Condenser	Aluminum fins Copper tube
Ambient temperature	45 C
Water tank / Cooler	Stainless steel / SS 304 / 160 liter
Physical dimensions	L-1200 x W-900 x H-1000 mm (approx.)
Controller (Panel)	Thermostatic adjustable temperature controller



# UNIT PARAMETERS

## Unit operating range

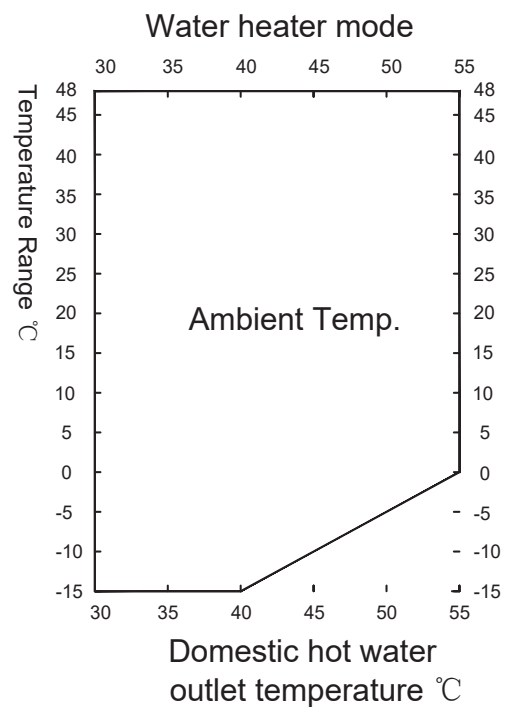
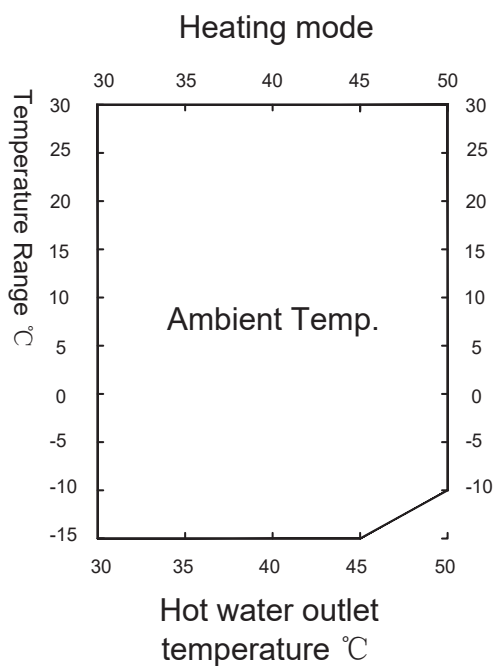
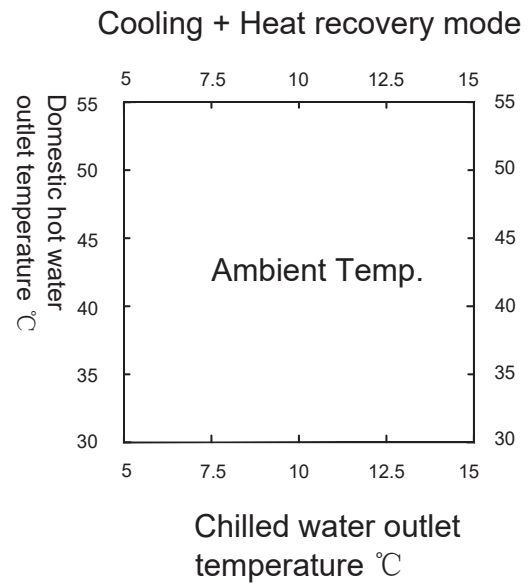
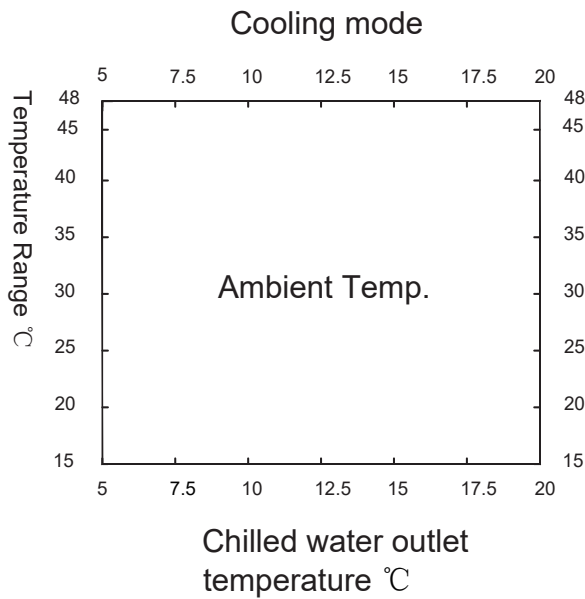



# Capacity Performance Table

## ■ Cooling capacity performance table

Ambient Temp.		48°C		45°C		40°C		35°C		30°C		25°C		20°C		15°C	
		capacity (kW)	power (kW)	capacity (kW)	power (kW)	capacity (kW)	power (kW)	capacity (kW)	power (kW)	capacity (kW)	power (kW)	capacity (kW)	power (kW)	capacity (kW)	power (kW)	capacity (kW)	power (kW)
Water outlet temperature	5°C	52.3	25.3	56.4	23.4	60.5	21.9	65	20.3	68.1	18.3	70.3	16.7	71.8	15.5	73.5	14.5
	7°C	56.5	25.7	61.1	23.9	64.9	22.4	69	20.8	72.3	18.8	74.6	17.1	76.3	15.9	77.5	14.9
	9°C	60.4	26.1	64.8	24.4	68.7	22.8	73.2	21.2	76.4	19.2	78.3	17.5	80	16.3	81.3	15.4
	12°C	66.3	26.5	70.6	24.8	74.8	23.1	79.1	21.5	82.4	19.5	84.2	17.8	86.3	16.7	87.6	15.7
	15°C	72.3	26.9	76.6	25.2	81.3	23.4	85.8	21.8	88.6	19.8	90.2	18.1	91.8	17	93.5	16



## Electrical parameter table

Model		ACCH
Maximum operating current (A)		55
L (R/S/T)	Cross section area (mm <sup>2</sup> )	25
	Number of roots	3
N	Cross section area (mm <sup>2</sup> )	6
	Number of roots	1
E	Cross section area (mm <sup>2</sup> )	16
	Number of roots	1





## Electrical Connection

- The unit is installed in combination Communication line connection diagram

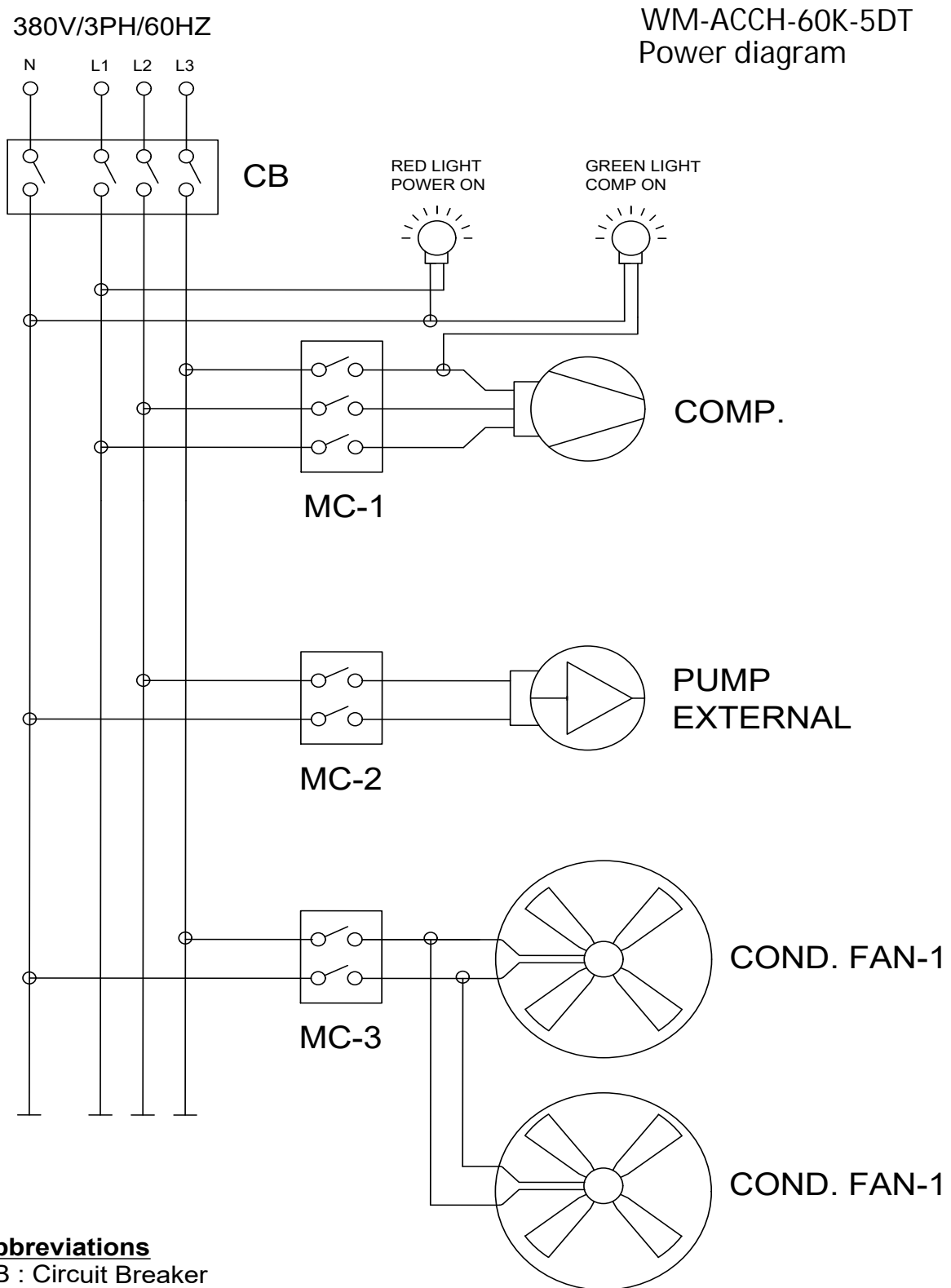

### Abbreviations

CB : Circuit Breaker  
MC-1 : Magnetic Contactor No.1  
H.P.S : High Pressure Switch  
T.C : Temperature Controller



## ACCH Series chiller parts

1. Water return to the chiller unit
2. Power ON/OFF indicator
3. Compressor ON/OFF indicator
4. External Pump ON/OFF Switch
5. Compressor
6. Up discharge condenser fan-1
7. Control panel
8. Shell and tube evaporator
9. Condenser fan-2
10. Water supply from the chiller unit
11. Condenser coil

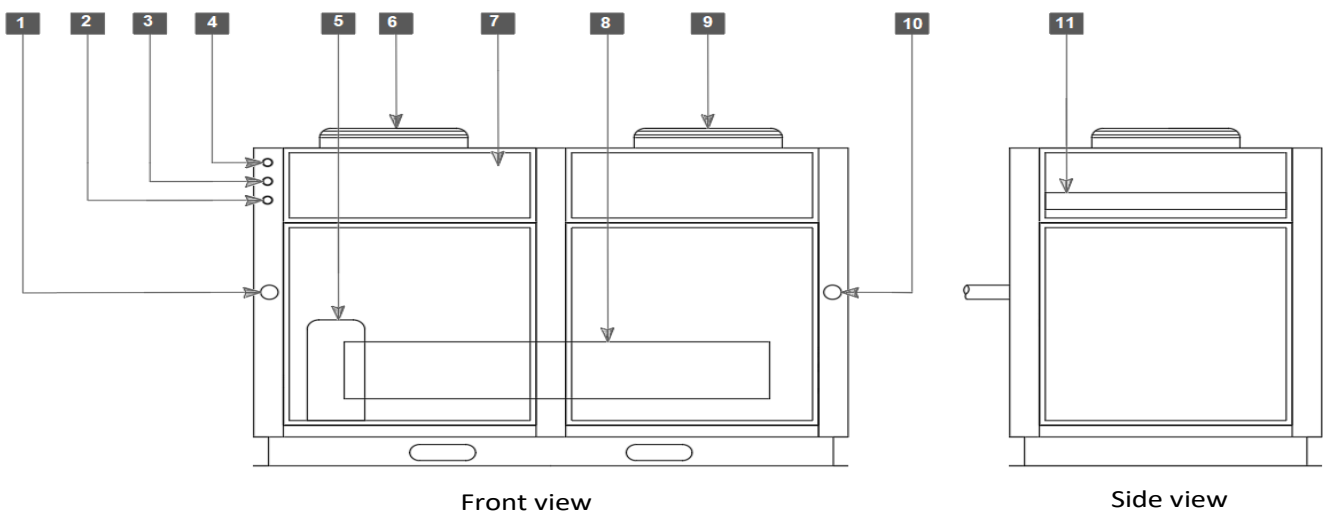

- Notes:**
1. The parameters in the figure are for reference only, the actual size shall prevail.
  2. The illustrated interface is the actual interface size of the unit; During installation, the nozzle must be larger than this size.



# UNIT INSTALLATION

## Space requirements for installation of Single unit combinations

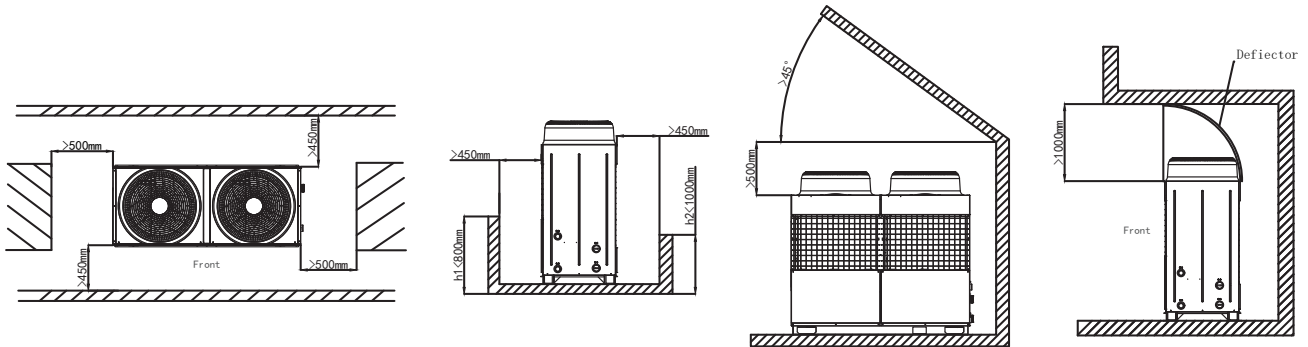

## Space requirements for installation of multiple unit combinations

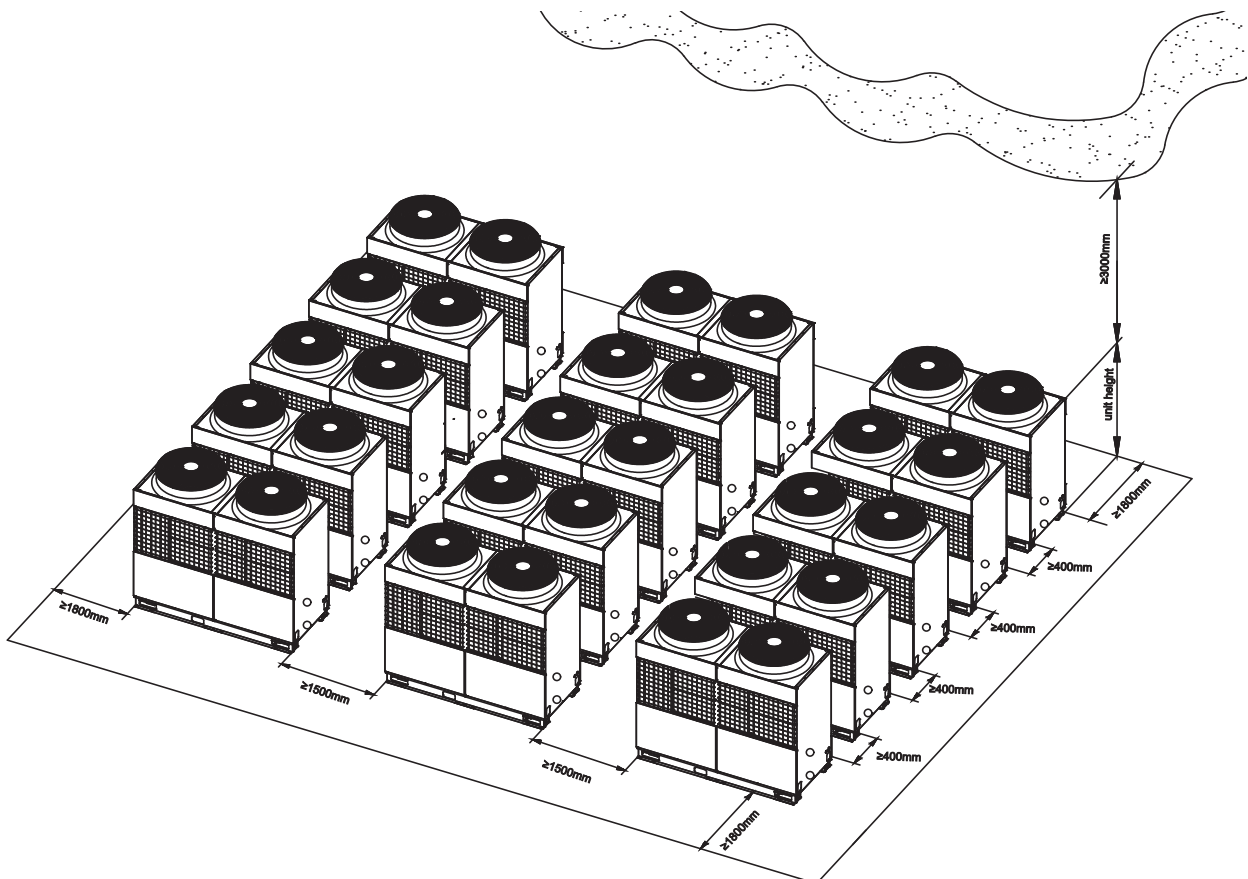



## Installation Foundation Diagram Of The Unit

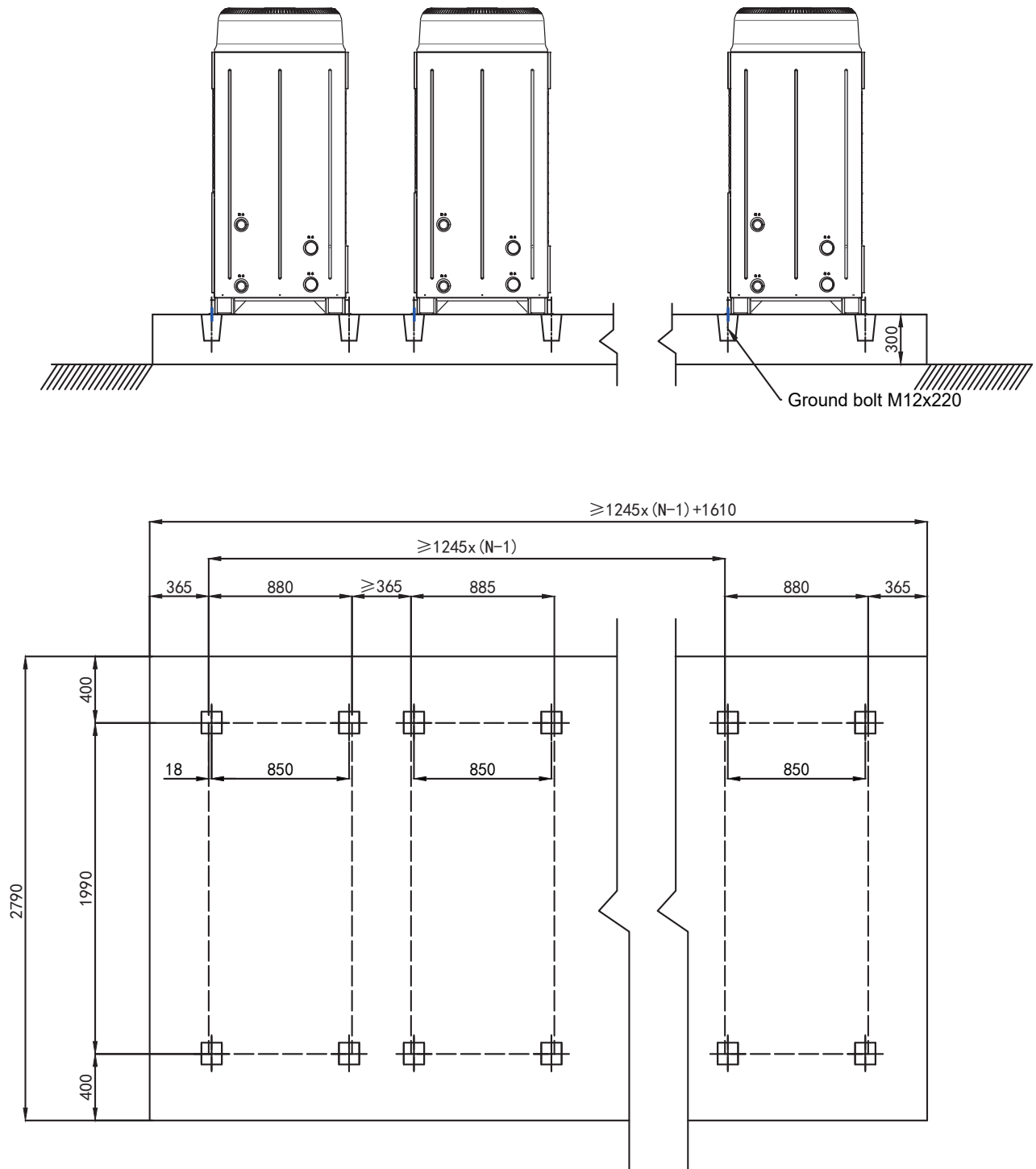

- Notes:**
1. The installation foundation must be able to withstand the unit operating pressure of the concrete floor or trough steel frame structure;
  2. N indicates the total number of installed modules.
  3. Each unit is fixed with 4 M12 bolts;
  4. Six 20mm thick rubber shock absorbers should be installed between the unit and the installation base;
  5. The installation base must be equipped with drainage facilities to facilitate the drainage of condensate and defrosting water.





# USAGE INSTRUCTIONS

## The Water Quality Requirement Standards Of The Chiller

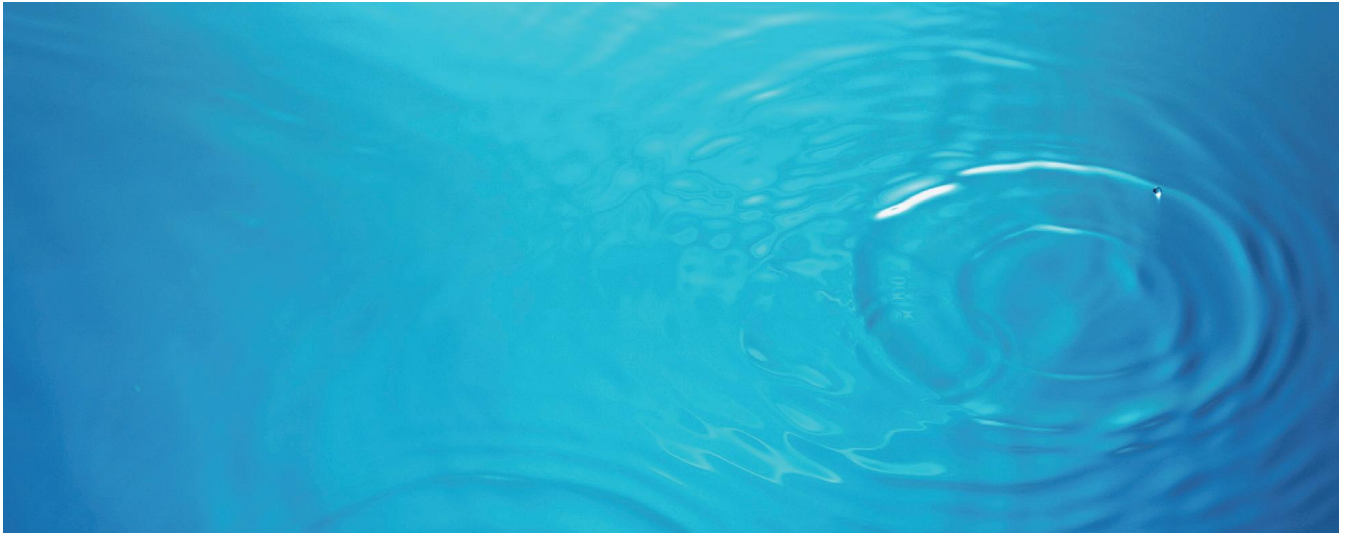

Project	Reference Value	Tendency	
		Corrosion	Scaling
PH(25°C)	7.5~9.0	○	○
Conductivity(25°C)	μS/cm	○	○
Cl <sup>-</sup>	mg(Cl <sup>-</sup> )/L	○	
SO <sub>2</sub> <sup>-</sup>	mg(SO <sub>2</sub> <sup>-</sup> )/L	○	
Total hardness	mg(CaCO <sub>3</sub> )/L		○
Fe	mg(Fe)/L	○	○
S <sub>2</sub> <sup>-</sup>	mg(S <sub>2</sub> <sup>-</sup> )/L	○	
NH <sup>+</sup>	mg(NH <sup>+</sup> )/L	○	
Free CO <sub>2</sub>	mg(CO <sub>2</sub> )/L	○	
Dissolved Oxygen	mg(O <sub>2</sub> )/L	○	
SiO <sub>2</sub>	mg(SiO <sub>2</sub> )/L		○
Turbidity	NTU	○	○

○ indicates factors related to corrosion or scaling tendency

**Notes:** 1. When the water quality exceeds this standard, corresponding water quality treatment should be carried out for the circulating water/supplementary water.  
2. Start the first inspection within 7-10 days of startup and operation, and conduct quarterly inspection during operation.



## Precautions For Adding Antifreeze To The Water System

- Common Antifreeze, such as ethylene glycol solution, is prone to stainless steel, copper and other metals. In serious cases, it may cause perforation and damage to metal structures. Therefore, it is necessary to add corrosion inhibitors to the ethylene glycol solution, or choose a combination solution of antifreeze, anti-corrosion agent, corrosion inhibitor, and scale inhibitor.
- Ethylene glycol and other antifreeze solutions are volatile, and the concentration when adding antifreeze for the first time should be the corresponding freezing point concentration+5%.
- Due to the continuous loss of antifreeze during the operation of the water system, and the addition of corrosion inhibitors with certain timeliness, it is necessary to regularly measure the actual proportion of antifreeze content in the system. Once it decreases, it should be replenished in a timely manner.

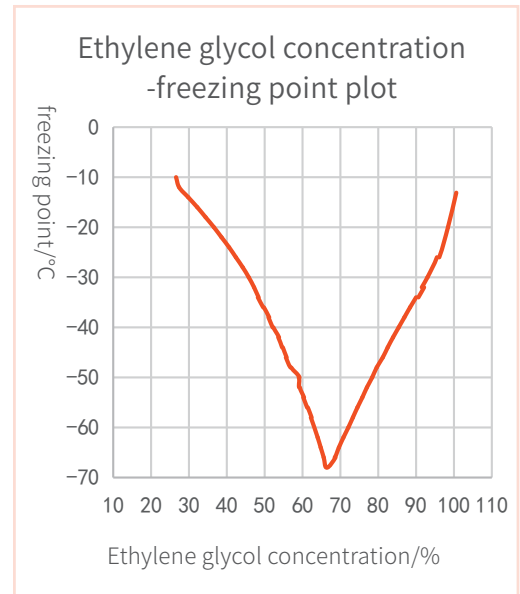

## Concentration Freezing Point Relationship Of Ethylene Glycol Solution

Freezing point °C	Ethylene glycol concentration %	Density (20°C) mg/cm <sup>3</sup>	Freezing point °C	Ethylene glycol concentration %	Density (20°C) mg/cm <sup>3</sup>	Freezing point °C	Ethylene glycol concentration %	Density (20°C) mg/cm <sup>3</sup>
-10	26.4	1.034	-44	54.6	1.074	-56	74.5	1.095
-12	27.2	1.038	-46	55.6	1.075	-54	75.8	1.096
-14	29.6	1.041	-48	56.8	1.077	-52	77	1.097
-16	32	1.044	-50	59	1.0786	-50	78.4	1.098
-18	34.2	1.048	-52	59.1	1.079	-48	79.6	1.1
-20	36.4	1.0506	-54	60.2	1.08	-46	81.2	1.101
-22	38.4	1.053	-56	61.2	1.081	-44	82.5	1.102
-24	40.4	1.056	-58	62.2	1.082	-42	83.9	1.103
-26	42.2	1.059	-62	64	1.084	-40	85.4	1.104
-28	44	1.061	-64	64.8	1.085	-38	86.9	1.105
-30	45.6	1.0627	-66	65.6	1.086	-36	88.4	1.107
-32	47	1.064	-68	66.3	1.087	-34	90	1.108
-34	48.2	1.066	-66	68.5	1.089	-32	91.5	1.109
-36	49.6	1.068	-64	69.6	1.09	-30	93	1.11
-38	51	1.07	-62	70.8	1.091	-26	95.5	1.111
-40	52.1	1.071	-60	72.1	1.092	-20	97.8	1.112
-42	53.6	1.073	-58	73.3	1.094	-13.1	100	1.113

# GET IN TOUCH!

windmason  
BREATHE THE FINEST

REVOLUTIONARY COOLING AND REFRIGERATION  
SOLUTION FOR A HEALTHY FUTURE

**INNOVATIVE GREEN AIR CONDITIONING**



windmason  
BREATHE THE FINEST

## CONTACT US



Landline:  
**+966 11 515 7284**



Whatsapp:  
**+966 54 328 8265**



Email:  
[Info@windmason.com](mailto:Info@windmason.com)



Web:  
[www.windmason.com](http://www.windmason.com)